



RIFORNIMENTO
AUTO



FUEL MANAGEMENT
SYSTEMS



KITS



POMPE



CONTALTRI



PISTOLE
CONTALTRI

SB325_X

CARATTERISTICHE

- CONDIZIONI DI LAVORO GRAVOSE
- VERSATILE
- SISTEMA DI SGANCIO/SICUREZZA
- DESIGN ERGONOMICO

SB325_X è la pistola automatica brevettata da PIUSI per AdBlue®. Progettata in conformità con le norme internazionali ISO/ FDIS 22241-4:2009, è dotata di sistema di esclusione e beccuccio in acciaio inox e di un involucro affidabile, ergonomico e flessibile che la protegge dall'invecchiamento e dai raggi UV. La sicurezza è garantita dal sistema di esclusione. Nel caso in cui inavvertitamente un veicolo parta lasciando la pistola nel serbatoio, il beccuccio è stato progettato in modo tale da staccarsi dalla pistola. Questo sistema permette anche una riparazione veloce inserendo semplicemente un nuovo beccuccio sulla pistola.

PERFORMANCE

FINO A

45 L/MIN

PORTATA

3,5 BAR

MAX

PRESSIONE D'ESERCIZIO



SB325_X



PACKAGING

CODICE	PESO		PACKAGING		
	KG	LBS	MM	INCH	PEZZI/BOX
FOO61700A	0,7	1,5	447X178X85	17,6X7X2,5	1



PISTOLE



FILTRAZIONE



MONITORAGGIO FLUIDI



ARROTOLATORI



ACCESSORI



MERCHANDISE

INDEX



ARIA



ANTIGELO



AdBlue®



BIODIESEL



DIESEL



ALIMENTI



BENZINA



GRASSO



KEROSENE



OLIO



ACQUA



LAVAVETRI

GRAFICO

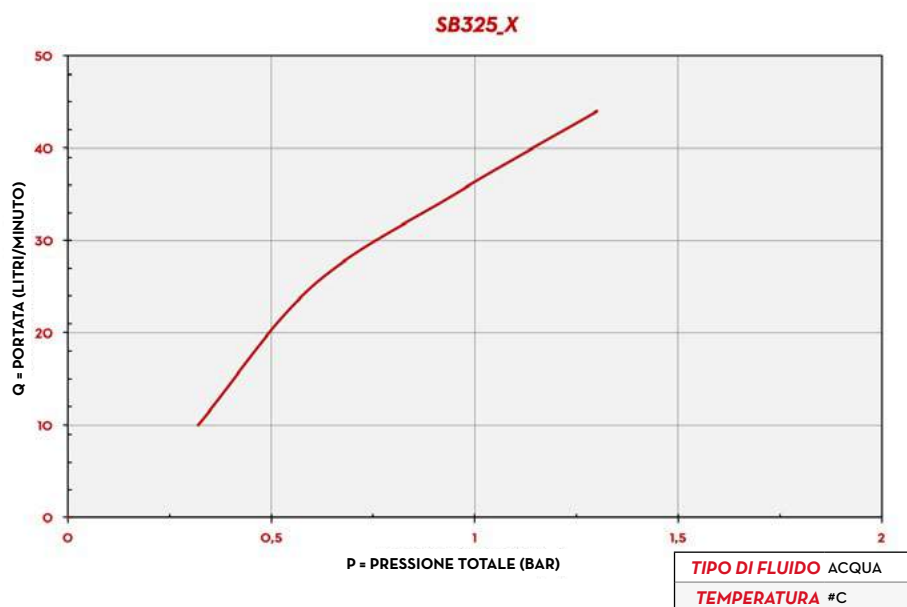

DIMENSIONI

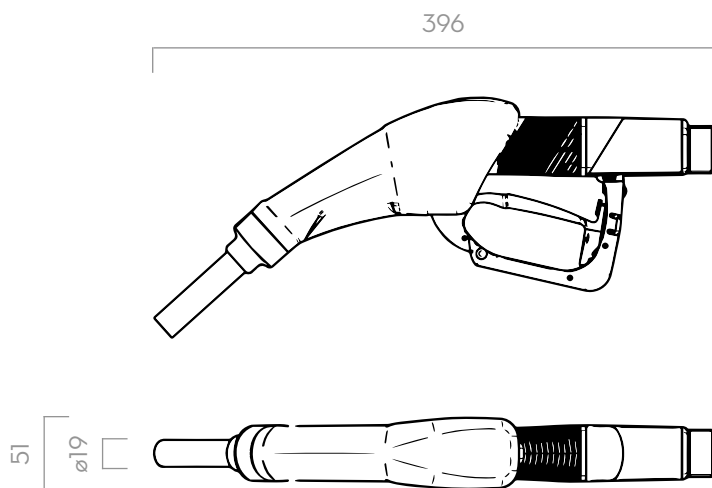

Dimensioni espresse in millimetri

DENTRO LA SCATOLA

- PISTOLA SB325_X
- MANUALE ISTRUZIONI

DETTAGLI



MATERIALI

- SPOUT: ACCIAIO INOX
- CORPO: TECNOPOLIMERO

DATI TECNICI

CODICE	DESCRIZIONE	TIPI DI FLUIDO	PORTATA		ADATTATORE MAGNETICO	CONTALITRI	PRESSIONE	INLET	RACCORDO	SPOUT
			L/MIN	GPM			BAR			EXT. Ø
FOO61700A	AUTOMATIC NOZZLE SB325_X		45	12	NO	NO	3,5	3/4"	SI	19 MM

SB325_X